

Contents

Page	1	Important information.
	2	Introduction.
	3	<i>In-Ceiling</i> and <i>In-Wall</i> features, plus declaration of conformity.
	4	<i>In-Ceiling</i> installation.
	5	Fine tuning of <i>In-Ceiling</i> speakers and technical specification.
	6	<i>In-Wall</i> installation.
	7	Fine tuning of <i>In-Wall</i> speakers and dB adjustments of Gold and Silver <i>In-Ceiling</i> and <i>In-Wall</i> loudspeakers.
	8	<i>In-Wall</i> technical specifications.
	9	Guarantee Statement.
	10 -11	Multi-lingual safety warnings- German, Italian, Spanish and French.

IMPORTANT INFORMATION

The CP Series *In-Ceiling* and *In-Wall* loudspeakers will provide long term satisfaction in terms of sound quality and reliability provided they are installed correctly, according to the instructions and conditions contained in this manual. Please read this installation guide carefully before proceeding. We assume the installer is trained and skilled in the correct and safe use of hand and power tools and has a working knowledge of local building and fire regulations/codes as well as experience of the conditions/services behind walls and ceilings into which these speakers will be installed. **IF IN DOUBT ABOUT YOUR ABILITY TO INSTALL THESE PRODUCTS SAFELY AND CORRECTLY PLEASE CONTACT YOUR LOCAL AUTHORISED MONITOR AUDIO DEALER OR CUSTOM INSTALLER.**



WARNINGS:

- A minimum depth of 190mm (7½ Inches) is required for the *In-Ceiling* back box to fit into recess. The *In-Wall* requires 98mm (4 Inches)
- The fixing clamps require a minimum of 25mm (1 Inch) of surface area around the cut-out hole to ensure a secure fixing!
- The fixing clamps will operate on ceilings or walls with a minimum thickness of 9mm (3/8 Inches) to a maximum depth of 32mm (1¼Inches)
- Do not attempt to fix these speakers to your ceiling or wall if you are unsure of your ability to provide a secure and safe fixing. **IF IN DOUBT CONTACT YOUR LOCAL AUTHORISED MONITOR AUDIO DEALER OR CUSTOM INSTALLER.**
- Ensure that there are no water pipes, air ducts or electricity cables running immediately behind the cut out area!
- Please work from secure steps or scaffold and avoid trailing wires for your safety and those around you.
- Always turn off the amplifier or other devices in the system when connecting these speakers

www.monitoraudio.co.uk

Introduction

Congratulations and thank you for purchasing this high performance Monitor Audio CP Series loudspeaker. This is no ordinary architectural speaker. Monitor Audio has taken great care to apply its award-winning loudspeaker technologies to create a hi-fidelity design, which promises exceptional sound quality and reliability. CP stands for 'Controlled Performance'. Each CP *In-Ceiling* or *In-Wall* product is fitted with its own rigid enclosure to make sure the sound is always the same, wherever it is fitted.

For all *In-Ceiling* and *In-Wall* applications, you can rely on the elevated standards of build quality and performance that have earned Monitor Audio's Bronze, Silver and Gold loudspeaker ranges acclaim from professionals around the world.

In designing the Bronze, Silver and Gold CP *In-Ceiling* and *In-Wall* speakers, Monitor Audio offers three levels of performance for a wide range of applications and budgets, but promises market-leading reliability and value in each case.

Speaker Location

We strongly recommend that these speakers be installed professionally so that positioning and fine-tuning can be successfully undertaken using sound measuring equipment, coupled with room layout experience and technical knowledge.

Your CP series *In-Ceiling* and *In-Wall* loudspeakers installed in your home theatre can be used as surround speakers in conjunction with freestanding speakers. If you are unsure about where to locate your surround speakers for optimum performance, please contact your Monitor Audio Dealer for advice.

When mounting your speakers in the ceiling, locate the speakers 0.6-2m (2 to 6 feet) behind your listening position. The speakers should be installed 2 to 3m (6 to 10 feet) apart centre to centre.

A Typical example is Shown below.

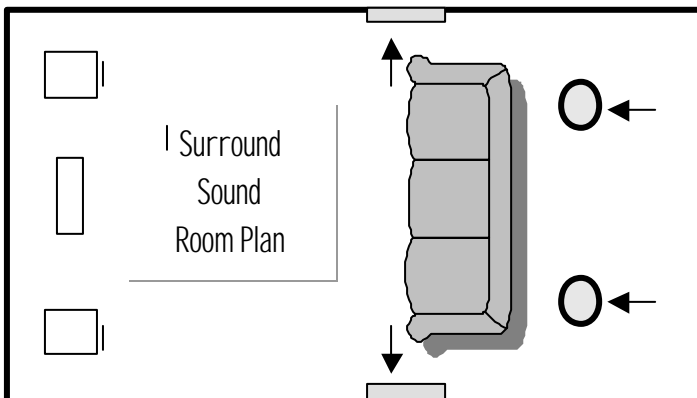

Fine tuning & Calibration

Your amplifier or A/V receiver manual will contain information and detailed instruction on fine tuning/calibrating your system so that the correct balance is achieved between the various speakers. It may be necessary to adjust the CP speakers as described in pages 4 and 6

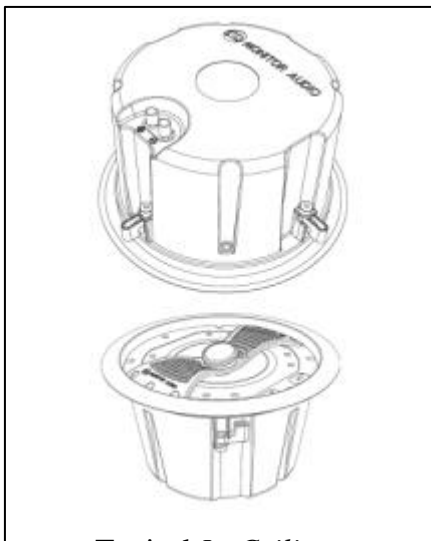

Typical *In-Ceiling*

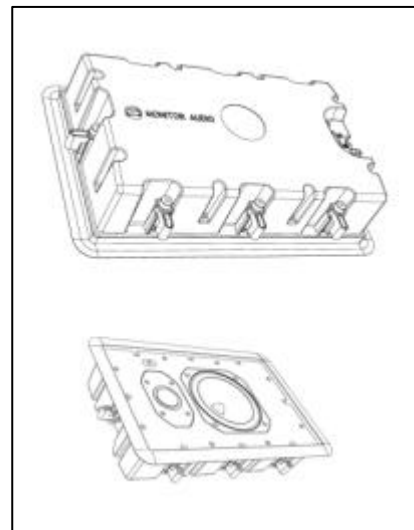

Typical *In-Wall*

Gold CP Features

Gold CP *In-Ceiling* speakers utilise our C-CAM[®] (Ceramic Coated Aluminium Magnesium alloy) cone, featuring *Rigid Surface Technology (RST[®])*. Impressions on the cone's surface are designed to eliminate bending, increase stiffness and lower mass when compared with conventional cone driver designs. The result is a much faster response, offering music reproduction that is closer to the original performance. A rigid die-cast metal chassis design features a vented rear section and provides extremely low distortion with typically higher output levels.

Additional high frequency and mid-range frequency controls allow the user to set-up the system precisely to obtain optimum performance within the listening environment. This inherent flexibility makes the Gold CP *In-Ceiling* speaker suitable for a wider range of demanding applications than that offered by its competitors. It promises a truly 'high-end' performance from a custom fit, discreetly installed speaker system.

Silver CP Features

Our C-CAM[®] (Ceramic Coated Aluminium Magnesium alloy) cone profiles and rubber surrounds maximise the potential of the driver mechanism. The new surrounds allow greater cone excursions with lower distortion and improved frequency response linearity. The flush cone edge provides a very smooth response and a natural, accurate sound. The Silver CP pivoting (***In-Ceiling only***) tweeter is based on Monitor Audio's famous 25mm gold C-CAM[®] dome. Improvements to the surround and motor system have extended the frequency response to 30kHz, so that it is ready to exploit new wide bandwidth digital audio formats such as SACD and DVD-A.

An additional high frequency control offers a fine-tuning option to allow the user to set-up the system precisely and obtain optimum performance within the listening environment. This additional flexibility makes the Silver CP *In-Ceiling* and *In-Wall* speakers suitable for a wider range of demanding residential and commercial applications.

Bronze CP Features

The Bronze drive unit, (MMP[®] Mk2) offers an advanced driver technology developed from Monitor Audio's original Metal Matrix Polymer cone material and uses a high-pressure injection moulding process to achieve different thickness at critical points in the cone geometry. MMP[®] Mk2 provides better stiffness and consistency and tighter production tolerances resulting in superior sonic performance. The new bass-mid chassis design has a vented rear section that reduces thermal power compression to deliver increased dynamic range and higher sound pressure levels. This venting also lowers distortion by balancing the pressure within the voice-coil motor system. It means clean, crisp bass and an even clearer mid-range performance.

High frequency performance has been improved by the evolution of the GCAM[®] tweeter. The new tweeter utilises a pivoting action (***In-Ceiling only***) to provide optimum imaging and flexible set-up options. The bespoke crossover uses high-grade polypropylene film capacitors, and low distortion inductors

Declaration of Conformity

<p>We, Monitor Audio Ltd. 24 Brook Road Rayleigh Essex SS6 7XL England</p> <p>Declare in own responsibility, that the products described in this manual are in compliance with technical standards: EN 50082-1 : 1998 EN 55013 : 2001 EN 50020 : 2002</p>		<p>Dean Hartley (Technical Director) Monitor Audio Ltd England</p>
---	--	--

Installation – In-Ceiling Units

The CP Series *In-Ceiling* loudspeakers will provide long term satisfaction in terms of sound quality and reliability provided they are installed correctly, according to the instructions and conditions contained in this manual. Please read this installation guide carefully before proceeding. We assume the installer is trained and skilled in the correct and safe use of hand and power tools, and has a working knowledge of local building and fire regulations/codes as well as experience of the conditions/services behind walls and ceilings into which these speakers will be installed. **IF IN DOUBT ABOUT YOUR ABILITY TO INSTALL THESE PRODUCTS SAFELY AND CORRECTLY PLEASE CONTACT YOUR LOCAL AUTHORISED MONITOR AUDIO DEALER OR CUSTOM INSTALLER.**

Parts List

PLEASE CHECK YOU HAVE THE FOLLOWING ITEMS IN THIS KIT BEFORE PROCEEDING:

- 1 x Complete speaker & tweeter assembly fitted to back box.
- 1 x Grille (which can be painted).
- 1 x Mounting cut out template (in packaging).
- 2 x Grille membrane (one for use during painting and the other as a clean replacement).
- 2 x Spare baffle fixing screws plus guarantee card in this manual.



WARNINGS:

- A minimum depth of 190mm (7½ Inches) is required for the back box to fit into recess.
- The fixing clamps require a minimum of 25mm (1 Inch) of surface area around the cutout hole to ensure a secure fixing!
- The fixing clamps will operate on ceilings with a minimum thickness of 9mm (3/8 Inches) to a maximum depth of 32mm (1¼ Inches).
- Do not attempt to fix these speakers to your ceiling if you are unsure of your ability to provide a secure and safe fixing. **IF IN DOUBT CONTACT YOUR LOCAL AUTHORISED MONITOR AUDIO DEALER.**
- Ensure that there are no water pipes, air ducts or electricity cables running immediately behind the cut out area!
- Please work from secure steps or scaffold and avoid trailing wires for your safety and those around you.
- Always turn off the amplifier or other devices in the system when connecting these speakers.

Procedure

1. Use template to locate position of cut out. Fig 1. The adhesive backing allows for repositioning a number of times.
2. Draw round diameter to define the perimeter of the cut out - 250mm (9 7/8 inches)
3. Remove template and cut hole.
4. Locate speaker cable and connect by pushing the terminals in and releasing to clamp the cables as shown below Fig 2.
5. Fit back box into prepared hole and tighten fixing clamps. These will move outwards on tightening! **DO NOT OVERTIGHTEN! Once contact is made 2-3 turns are all that is required.**
6. Fit front Baffle if previously removed and check for sound quality before fitting the grille.
7. Paint at a time to suit. Use paint masks (membrane) supplied and replace with new item supplied.
- 8 **TO FINE-TUNE THE SPEAKERS PLEASE REFER TO PAGE 4 AND 6.**

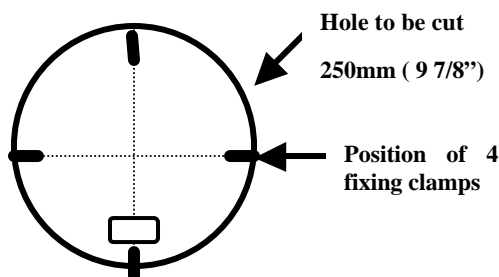

In-Ceiling Template

Fig 1

Not to scale

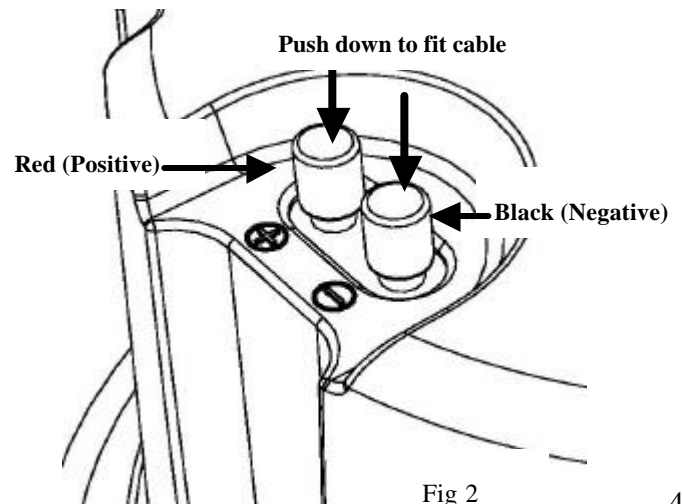

Fig 2

Fine-tuning the loudspeakers

The following adjustments can be made to your CP in-ceiling loudspeakers as follows:

1. Pivoting tweeters (all CP *In-Ceiling* models) can be tilted up to 18 degrees in all directions to provide optimum coverage if the following applies:
2. If the speakers are widely separated such that the music fails to blend into a central image when operated in stereo mode then tilt the tweeter towards the listening area.
3. If the Soundstage seems too confined tilt the tweeter away from the listening area.
4. For further fine-tuning options of your CP *In-Ceiling* speakers please go to page 6.

Specifications - *In-Ceiling*

Model	Gold CP <i>In-Ceiling</i>	Silver CP <i>In-Ceiling</i>	Bronze CP <i>In-Ceiling</i>
Frequency response	55Hz – 30KHz	60Hz – 30KHz	62Hz – 22 KHz
Impedance (nominal)	8 Ohms	8 Ohms	8 Ohms
Sensitivity (1W@1M)	89dB	89dB	88dB
Maximum SPL	106.5 dBA	105.8 dBA	105 dBA
Power handling	120W	100W	80W
Recommended Amp requirements	30-120W	30-100W	20-80W
Bass alignment	Sealed enclosure	Sealed enclosure	Sealed enclosure
Drive unit complement bass	1x 6.5" C-CAM bass driver featuring RST technology	1x 6" C-CAM bass driver	1x 6.5" MMP2 second generation Metal Matrix Polymer
Drive unit complement tweeter	Pivoting 25mm C-CAM gold alloy dome with high power ceramic magnet system	Pivoting 25mm C-CAM gold alloy dome with rare earth magnet	Pivoting 25mm C-CAM gold alloy dome with rare earth magnet
Overall diameter	281mm (11 1/16 inch)	281mm (11 1/16 inch)	281mm (11 1/16 inch)
Overall depth	181mm (7 1/8 inch)	181mm (7 1/8 inch)	181mm (7 1/8 inch)
Cut-out hole diameter	250mm (9 7/8 inch)	250mm (9 7/8 inch)	250mm (9 7/8 inch)
Mounting depth mm (inch)	175mm (6 7/8 inch)	175mm (6 7/8 inch)	175mm (6 7/8 inch)
Controls	+3db / 0dB / -3dB High frequency attenuation switch. +3db / 0dB / -3dB Mid-range frequency attenuation switch.	+3db / 0dB / -3dB High frequency attenuation switch	N/A
Fixing type	4 position 'dog' type fixings	4 position 'dog' type fixings	4 position 'dog' type fixings
Connection	Gold plated 'push' type terminals	Gold plated 'push' type terminals	Gold plated 'push' type terminals
Baffle material	MDF	MDF	MDF
Back box/ mounting flange material	Mineral filled ABS plastic (UL V1 fire rated)	Mineral filled ABS plastic (UL V1 fire rated)	Mineral filled ABS plastic (UL V1 fire rated)
Unit weight Kg (lb)	3.0Kg (6.6lb)	2.5Kg (5.5lb)	2.4Kg (5.3lb)

Installation - In-Wall Units

The CP Series *In-Wall* loudspeakers will provide long term satisfaction in terms of sound quality and reliability provided they are installed correctly, according to the instructions and conditions contained in this manual. Please read this installation guide carefully before proceeding. We assume the installer is trained and skilled in the correct and safe use of hand and power tools, and has a working knowledge of local building and fire regulations/codes as well as experience of the conditions/services behind walls and ceilings into which these speakers will be installed. **IF IN DOUBT ABOUT YOUR ABILITY TO INSTALL THESE PRODUCTS SAFELY AND CORRECTLY PLEASE CONTACT YOUR LOCAL AUTHORISED MONITOR AUDIO DEALER OR CUSTOM INSTALLER.**

Parts List

PLEASE CHECK YOU HAVE THE FOLLOWING ITEMS IN THIS KIT BEFORE PROCEEDING:

- 1 x Complete speaker & tweeter assembly fitted to back box.
- 1 x Grille (which can be painted).
- 1 x Mounting cut out template (in packaging).
- 2 x Grille membrane (one for use during painting and the other as a clean replacement).
- 2 x Spare baffle mounting screws plus guarantee card in this manual.



WARNINGS:

- A minimum depth of 98mm (4 Inches) is required for the back box to fit into wall/ceiling recess.
- The fixing clamps require a minimum of 25mm (1 Inch) of surface area around the cut-out hole to ensure a secure fixing!
- The fixing clamps will operate on walls with a minimum thickness of 9mm (3/8 Inches) to a maximum depth of 32mm (1¼ Inches).
- Do not attempt to fix these speakers to your wall if you are unsure of your ability to provide a secure and safe fixing. **IF IN DOUBT CONTACT YOUR LOCAL AUTHORISED MONITOR AUDIO DEALER.**
- Ensure that there are no water pipes, air ducts or electricity cables running immediately behind the cut out area!
- Please work from secure steps or scaffold and avoid trailing wires for your safety and those around you.
- Always turn off the amplifier or other devices in the system when connecting these speakers.

Procedure

1. Secure template in position. Please note that the outer profile indicates size of cut-out. Fig 3. The adhesive backing allows for repositioning a number of times.
2. Cut hole and Locate speaker cable and connect as shown below Fig 4.
3. Fit back box into prepared hole and tighten fixing clamps. These will move outwards on tightening! **DO NOT OVERTIGHTEN! Once contact is made 2-3 turns are all that is required.**
4. Paint at a time to suit. Use paint masks (membrane) supplied and replace with new item supplied.
5. **TO FINE-TUNE THE SPEAKERS PLEASE REFER TO PAGE 6.**

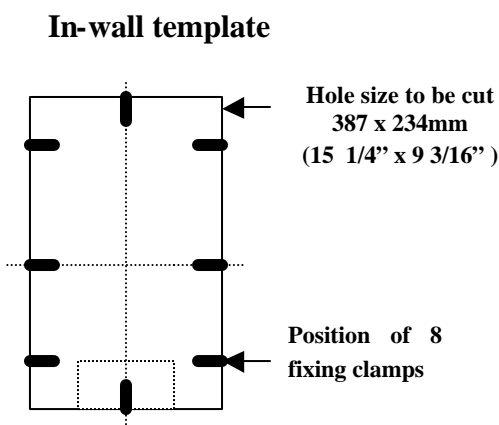

Fig 3

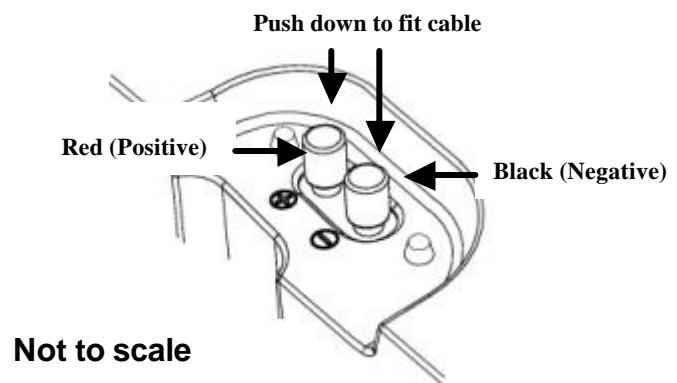

Fig 4

Fine-tuning - *In-Ceiling and In-wall speakers*

The following adjustments can be made to your CP *In-Ceiling* and *In-Wall* loudspeakers as follows:

Adjusting H.F (High Frequency) control

(Silver CP and Gold CP models only)

The factory H.F setting provides a flat or 0dB level, which will suit the majority of typical installations. However, it is possible to fine-tune the sound from the CP speakers to suit a room's characteristics or preferred listening tastes by using the following as a guide: -

- a. Setting the switch in the +3dB position will add brightness and additional clarity to the system. This may be effective in a room with a large amount of soft furnishings.
- b. Setting the switch in the -3dB position will reduce the brightness on the system and provide a duller sound. This may be effective in a room with a lack of soft furnishings, or in an installation with a wooden floor.

Adjusting M.F (Mid-range Frequency) control

(Gold CP models only)

The factory M.F setting provides a flat or 0dB level, which will suit the majority of typical installations. However, it is possible to fine-tune the sound from the Gold CP *In-Ceiling* and *In-Wall* speakers to suit a room's characteristics or preferred listening tastes by using the following as a guide: -

- a. Setting the switch in the +3dB position will add presence and additional clarity to the system, particularly in the vocal region. This may be effective for better resolution of dialogue and speech, or in an installation where the listening position is a large distance from the speaker.
- b. Setting the switch in the -3dB position will reduce the presence and the system will sound more 'laid back'. This may be effective where the speaker will be played for background music, or where the listening position is situated close to the speaker.

Technical Specifications CP In-Wall

Model	Gold CP In-Wall	Silver CP In-Wall	Bronze CP In-Wall
Frequency response	55Hz – 30KHz	60Hz – 30KHz	62Hz – 22 KHz
Impedance (nominal)	8 Ohms	8 Ohms	8 Ohms
Sensitivity (1W@1M)	89dB	89dB	88dB
Maximum SPL	106.5 dBA	105.8 dBA	105 dBA
Power handling	120W	100W	80W
Recommended Amp requirements	30-120W	30-100W	20-80W
Bass alignment	Sealed enclosure	Sealed enclosure	Sealed enclosure
Drive unit complement bass	1x 6.5" C-CAM bass driver featuring RST technology	1x 6" C-CAM bass driver	1x 6.5" MMP2 second generation Metal Matrix Polymer
Drive unit complement tweeter	25mm C-CAM gold alloy dome with high power ceramic magnet system and rear low resonance chamber	25mm C-CAM gold alloy dome with rare earth magnet	25mm C-CAM gold alloy dome with rare earth magnet
Overall size	423mm high x 270 wide (16 11/16 inches x 10 11/16 inches)	423mm high x 270 wide (16 11/16 inches x 10 11/16 inches)	423mm high x 270 wide (16 11/16 inches x 10 11/16 inches)
Overall depth	100mm (3 15/16 inches)	100mm (3 15/16 inches)	100mm (3 15/16 inches)
Cut-out hole size	387mm high x 234mm wide (15 1/4 inches x 9 1/4 inches)	387mm high x 234mm wide (15 1/4 inches x 9 1/4 inches)	387mm high x 234mm wide (15 1/4 inches x 9 1/4 inches)
Mounting depth	95mm (3 3/4 inches)	95mm (3 3/4 inches)	95mm (3 3/4 inches)
Controls	+3db / 0dB / -3dB High frequency attenuation switch. +3db / 0dB / -3dB Mid-range frequency attenuation switch.	+3db / 0dB / -3dB High frequency attenuation switch	Not Applicable
Fixing type	8 position 'dog' type fixings	8 position 'dog' type fixings	8 position 'dog' type fixings
Connection	Gold plated 'push' type terminals	Gold plated 'push' type terminals	Gold plated 'push' type terminals
Baffle material	MDF	MDF	MDF
Back box/ mounting flange material	Mineral filled ABS plastic (UL V1 fire rated)	Mineral filled ABS plastic (UL V1 fire rated)	Mineral filled ABS plastic (UL V1 fire rated)
Unit weight Kg (lb)	4.3Kg (9.5lb)	3.0Kg (6.6lb)	3.0Kg (6.6lb)

Guarantee and Service

The guarantee becomes valid upon completion of the attached guarantee card and its return within 30 days of purchase.

This guarantee is void if the serial number has been removed or defaced.

This equipment has been fully tested prior to dispatch from the factory. Both the craftsmanship and the performance of this product is guaranteed against manufacturing defects for the period of three years from the date of purchase (see conditions below), provided that the product was supplied by an authorised Monitor Audio retailer under the consumer sale agreement. (The words 'consumer sale' shall be construed in accordance with section 15 of the supply of goods act 1973). Monitor Audio accepts no responsibility for defects arising from accident, misuse, abuse, wear and tear, modification or operation outside of that specified within this instruction manual. Neither will responsibility be accepted for damage or loss occurring during transit to or from the parties claiming under this guarantee.

This guarantee covers both labour and parts. The liability of Monitor Audio is limited to the cost of repair or replacement of the defective parts (at the discretion of Monitor Audio) and under no circumstances extends to consequential losses or damage.

Claims under this Guarantee

The equipment should be returned in its packaging to the original supplier where possible, or to any other authorised Monitor Audio dealer. If it is not possible to return the equipment by hand, then it should be sent carriage prepaid via a reputable carrier. If the original packing is not available replacement packaging can be purchased from Monitor Audio. If you have any difficulties complying with these requirements please contact us at the following address:

Monitor Audio Ltd.
Unit 2, 24 Brook Road
Rayleigh
Essex
SS6 7XL
England

Tel: 44 (0) 1268 740580
Fax: 44 (0) 1268 740589
Internet: www.monitoraudio.co.uk
Email: info@monitoraudio.co.uk

This guarantee does not affect the statutory rights of the consumer under UK law and or relevant consumer laws in other countries or states.

Monitor Audio reserve the right to alter specifications at any time without notice if it is considered that an improvement can be made to the product.

Warnungshinweis

Die zum Wand/Decken-Einbau vorgesehenen Lautsprecher der CP Serie werden Ihnen auf lange Zeit mit ihrer vorzüglichen Tonqualität und Zuverlässigkeit viel Freude bereiten, vorausgesetzt, dass sie vorschriftsmäßig nach den in diesem Handbuch angegebenen Anleitungen und Bedingungen eingebaut werden. Lesen Sie bitte vor Beginn der Arbeiten diese Installationsanleitungen sorgfältig, da wir voraussetzen, dass der Installateur im vorschriftsmäßigen und sicheren Gebrauch von Elektrowerkzeugen unterwiesen und erfahren ist. Es wird ebenso vorausgesetzt, dass er ausreichende Kenntnisse der örtlichen Bau und Brandschutzbestimmungen besitzt, sowie entsprechende Erfahrung des Unterputzzustandes und der eventuell vorhandenen Leitungen in Wänden und Zimmerdecken besitzt, in welche diese Lautsprecher eingebaut werden sollen. **SOLLTEN SIE DARAN ZWEIFELN; DIESE ARBEITEN MIT SICHERHEIT- UND ORDNUNGSGEMÄSS AUSFÜHREN ZU KÖNNEN, WENDEN SIE SICH BITTE AN IHREN AUDIO - VERTRAGSHÄNDLER.**



WARNUNGSHINWEIS:

- Es wird eine Mindesteinbautiefe von 190 mm (7.5 Zoll) für den Deckeneinbau der Backbox benötigt. Für den Wandeinbau sind 98 mm (4 Zoll) vorzusehen.
- Die Befestigungsklemmen benötigen eine Oberfläche von 25 mm (1 Zoll) um das ausgeschnittene Loch herum, um eine sichere Befestigung zu gewähren!
- Die Befestigungsklemmen können bei Decken oder Wänden mit einer Mindestdicke von 9 mm (0,35 l) bis zu einer Mindestdiefe von 32 mm (1,25 Zoll) angewendet werden
- Versuchen Sie nicht, diese Lautsprecher an Ihrer Wand oder Decke anzubringen, wenn Sie nicht voll überzeugt sind, dass Sie imstande sind, diese vorschriftsmäßig und sicher zu montieren. **IM ZWEIFELSFALLE WENDEN SIE SICH BITTE AN IHREN ZUGELASSENEN ÖRTLICHEN AUDIOHÄNDLER.**
- Vergewissern Sie sich, dass sich keine Wasser- Luft- oder Elektroleitungen hinter dem Ausschnitt befinden!
- Benutzen Sie bitte immer nur sichere Tritte oder Leitergerüste und vermeiden Sie im Interesse Ihrer Sicherheit sowie der aller anwesenden Personen herabhängende und auf dem Boden schleifende Kabel und Leitungen.
- Bei Anschluss dieser Lautsprecher müssen die Verstärker sowie alle weiteren Geräte im System ausgeschaltet sein.

Avvertimenti

La Serie CP di altoparlanti incassati nel soffitto e nelle pareti offrirà un ottimo funzionamento in termini di qualità Sonora ed affidabilità, purché gli altoparlanti siano installati correttamente, seguendo le istruzioni e le condizioni contenute in questo manuale. Si prega di leggere attentamente questa guida all'installazione prima di procedere, poiché presumiamo che l'installatore sia addestrato e sia in grado di utilizzare gli attrezzi manuali ed elettrici. Ed abbia inoltre una conoscenza operativa dell'edificio locale e delle norme/codici antincendio e conosca le condizioni/i servizi dietro pareti e soffitti nei quali saranno installati questi altoparlanti. **IN CASO DI DUBBI SULLA PROPRIA ABILITÀ AD EFFETTUARE QUESTA INSTALLAZIONE IN MODO CORRETTO E SICURO, SI REGA DI CONTATTARE IL PROPRIO CONCESSIONARIO LOCALE AUTORIZZATO ALLA VENDITA DI APPARECCHI AUDIO.**



ATTENZIONE:

- E' necessaria una profondità minima di 190 mm perché la cassa posteriore possa essere installata nel vano **del soffitto**. Quella da incassare nella **parete** necessita di uno spazio di 98 mm.
- I dispositivi di fissaggio necessitano di una superficie minima di 25 mm intorno al foro intagliato per assicurare un fissaggio sicuro!
- I dispositivi di fissaggio saranno funzionali in soffitti e pareti che abbiano uno spessore di almeno 9 mm fino ad uno spessore massimo di 32 mm.
- Non si deve tentare di fissare questi altoparlanti in un soffitto o una parete se non si è certi della propria abilità di effettuare un'installazione appropriata e sicura. **IN CASO DI DUBBI CONTATTARE IL PROPRIO CONCESSIONARIO LOCALE AUTORIZZATO ALLA VENDITA DI APPARECCHI AUDIO.**
- Accertarsi che non vi siano di tubi dell'acqua, condotti d'aria o cavi elettrici installati appena dietro l'area intagliata!
- Lavorare su scale o impalcature sicure ed evitare di tirare dei fili per la propria sicurezza e quella di altre persone.
- Spegnere sempre l'amplificatore o altri dispositivi dell'impianto quando si collegano questi altoparlanti.

Advertencias

La CP Series de altavoces de empotrado en el techo y en la pared ofrecerán una satisfacción a largo plazo en concepto de calidad del sonido y fiabilidad, siempre y cuando se instalen correctamente, según las instrucciones y condiciones contenidas en este manual. Antes de proceder, lea detenidamente esta guía de instalación en la que se supone que el instalador está capacitado y es hábil en el uso correcto y seguro de herramientas manuales y eléctricas, y que tiene conocimientos prácticos de las regulaciones / códigos locales en materia de construcción e incendios, así como experiencia en cuanto a las condiciones / servicios que se encuentran detrás de los techos y paredes en los que se instalarán estos altavoces. **EN CASO DE DUDA DE QUE SEA CAPAZ DE INSTALAR ESTOS DISPOSITIVOS DE UNA MANERA SEGURA Y CORRECTA, SÍRVASE CONTACTAR CON SU DISTRIBUIDOR AUTORIZADO LOCAL DE AUDIO MONITORES**



ADVERTENCIAS:

- Se requiere una profundidad mínima de 190 mm (7,5 pulgadas) para que la caja de respaldo de empotrado **en el techo** quepa en el rebaje. La de empotrado **en la pared** requiere de 98 mm (4 pulgadas)
- ¡Las grapas de fijación requieren un área de superficie de 25 mm (1 pulgada), como mínimo, alrededor del agujero perforado para garantizar una fijación segura!
- Las grapas de fijación servirán en techos o paredes con un espesor mínimo de 9 mm (0,35 pulgadas) hasta una profundidad máxima de 32 mm (1,25 pulgadas)
- No intente instalar estos altavoces en el techo o pared si no está seguro de que sea capaz de ofrecer una instalación correcta y segura. **EN CASO DE DUDA CONTACTE CON SU DISTRIBUIDOR AUTORIZADO LOCAL DE AUDIO MONITORES.**
- ¡Cerciórese de que no haya tuberías de agua, ductos de aire o cables eléctricos que pasen inmediatamente por detrás del área perforada!
- Para la instalación use por favor escaleras o andamiaje y evite dejar alambres colgados por su propia seguridad y la de los que le rodean.
- Siempre apague el amplificador u otros dispositivos del sistema cuando conecte estos altavoces.

Avertissements

La série CP de haut-parleurs encastrés dans les murs et les plafonds fourniront une satisfaction à long terme quant à la qualité du son et à la fiabilité, à condition d'être installés correctement, conformément aux instructions et aux conditions contenues dans cette notice. Lisez attentivement cette notice avant de commencer l'installation. Nous supposons que l'installateur est formé et compétent et qu'il sait utiliser les outils à main et les outils électriques correctement et d'une manière sûre. Nous supposons également qu'il a une connaissance pratique des règlements/codes locaux relatifs aux constructions et aux incendies et qu'il a une expérience des conditions/services derrière les murs et les plafonds dans lesquels ces haut-parleurs seront installés. **SI VOUS AVEZ UN DOUTE QUELCONQUE SUR VOTRE CAPACITÉ D'INSTALLER CES HAUT-PARLEURS CORRECTEMENT ET D'UNE MANIÈRE SÛRE, CONTACTEZ VOTRE REVENDEUR LOCAL AGRÉÉ DE MATERIEL HI-FI.**



AVERTISSEMENTS :

- Il faut une profondeur d'au moins 190 mm pour encastrer le boîtier arrière dans le **plafond**. La profondeur nécessaire pour l'encastrement dans le **mur** est de 98 mm.
- Les brides de fixation ont besoin d'une surface d'environ 25 mm autour du trou découpé pour fournir une fixation ferme !
- Les brides de fixation sont adéquates pour être utilisées sur des plafonds et des murs d'une épaisseur minimum de 9 mm et d'une profondeur maximum de 32 mm.
- N'essayez pas de fixer ces haut-parleurs dans votre plafond ou dans votre mur si vous n'êtes pas certain de pouvoir obtenir une fixation ferme et sûre. **EN CAS DE DOUTE, CONTACTEZ VOTRE REVENDEUR LOCAL AGRÉÉ DE MATERIEL HI-FI.**
- Assurez-vous qu'il n'y a pas de conduites d'eau, de conduits d'air ni de câbles électriques juste derrière l'endroit prévu d'encastrement.
- Travaillez sur un escabeau ou sur un échafaudage sûr et évitez de laisser traîner des fils électriques pour votre sécurité et celle de ceux autour de vous.
- Mettez toujours hors tension l'amplificateur ou les autres dispositifs dans le système lorsque vous connectez ces haut-parleurs.